

IN THE MATTER OF NEW PLAN	*	BEFORE THE COUNTY
HOLDINGS, LLC – PETITION	*	BOARD OF APPEALS
FOR VARIANCE	*	FOR
8700 Liberty Road		
(Liberty Plaza Shopping Center)		
2 <sup>nd</sup> Election District	*	BALTIMORE COUNTY
4 <sup>th</sup> Councilmanic District	*	Case No. CBA-12-192-A
Zoning Case No. 2012-0192-A	*	

\* \* \* \* \*

**REMAND ORDER TO ADMINISTRATIVE LAW JUDGE**

This matter comes before this Board on appeal filed by the People’s Counsel for Baltimore County from a decision of the Administrative Law Judge, dated April 4, 2012, in which Petitioner requested variance relief related for signage for the Liberty Plaza Shopping Center.

Shortly after People’s Counsel filed its appeal, the parties met to discuss the concerns of People’s Counsel, which centered around a freestanding joint identification sign proposed at the entrance to the shopping center on Liberty Road (referenced as Sign 7 on the Plan to Accompany Petition for Variance and in the Opinion and Order). People’s Counsel was concerned over the size of the proposed sign.

As a result of those discussions, the parties have reached a compromise position as to a reduction in size of the disputed joint identification sign. The parties have jointly requested that the Board of Appeals remand the case back to the Administrative Law Judge for his consideration of a reduction of the variance granted for the

freestanding joint identification sign from a maximum sign area/face of 281.67 square feet down to a maximum sign area/face of 255 square feet as depicted on the attached **Exhibit 1**. The parties acknowledge that they are satisfied with all other relief granted in the April 4, 2012 Opinion and Order, and reconsideration should be limited to the requested reduction in Sign 7.

Upon consideration of the Joint Motion for Remand, therefore, it is this 31<sup>st</sup> day of May 2012, by the County Board of Appeals for Baltimore County,

ORDERED that the Joint Motion for Remand be and it is hereby GRANTED;

and

ORDERED that the above-captioned case be and is hereby REMANDED to the Administrative Law Judge for further review and consideration consistent with this Motion.

COUNTY BOARD OF APPEALS  
FOR BALTIMORE COUNTY

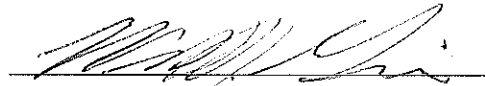

WENDELL H. GRIER, CHAIRMAN

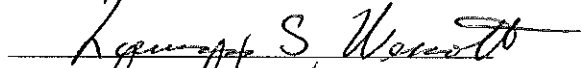

LAWRENCE S. WESCOTT

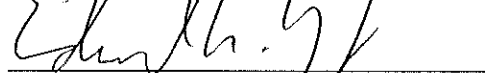

EDWARD W. CRIZER, JR.

EXHIBIT 1

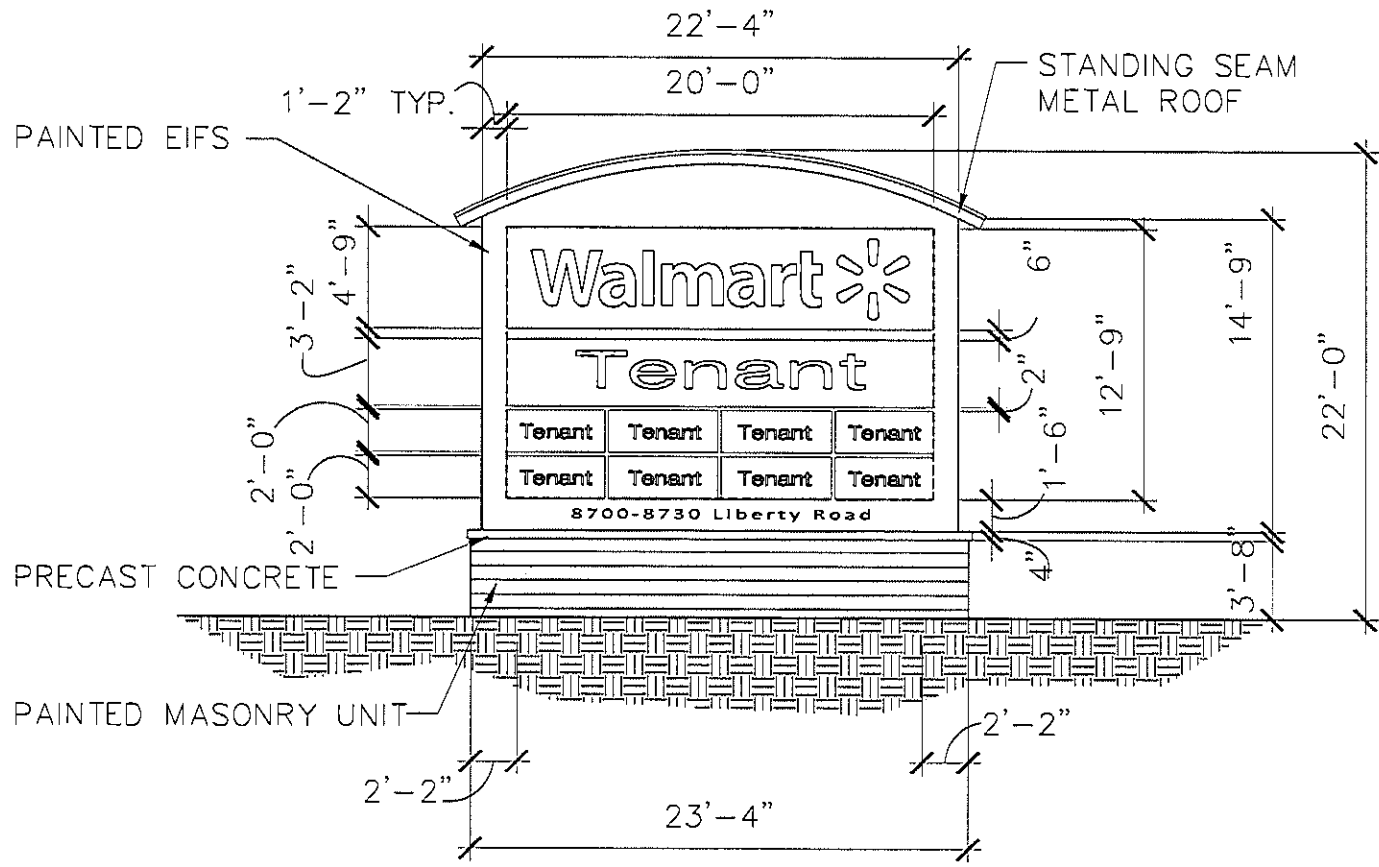

$20'-0" \times 12'-9" = 255 \text{ sf}$